



DICARRIER

FOR THE DIRECT IMPINGEMENT GAS SYSTEM

FOR THE AR-15 PLATFORM

SUPERLATIVEARMS® **EMAIL** sales@suparms.com **PHONE** 727-849-6880
6612 Osteen Rd | Unit 338 | New Port Richey, FL 34653 www.SUParms.com

BOLT CARRIER GROUP COMPONENTS |

Shown with optional bolt assembly (bolt, cam pin, firing pin, and firing pin retainer)

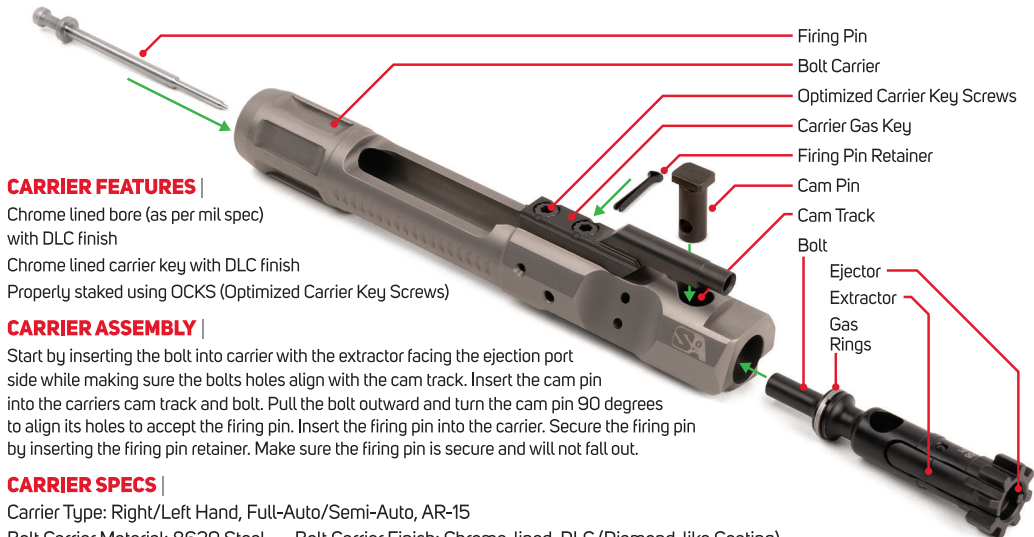

CARRIER FEATURES |

Chrome lined bore (as per mil spec)
with DLC finish

Chrome lined carrier key with DLC finish

Properly staked using OCKS (Optimized Carrier Key Screws)

CARRIER ASSEMBLY |

Start by inserting the bolt into carrier with the extractor facing the ejection port side while making sure the bolts holes align with the cam track. Insert the cam pin into the carriers cam track and bolt. Pull the bolt outward and turn the cam pin 90 degrees to align its holes to accept the firing pin. Insert the firing pin into the carrier. Secure the firing pin by inserting the firing pin retainer. Make sure the firing pin is secure and will not fall out.

CARRIER SPECS |

Carrier Type: Right/Left Hand, Full-Auto/Semi-Auto, AR-15

Bolt Carrier Material: 8620 Steel

Bolt Carrier Finish: Chrome-lined, DLC (Diamond-like Coating)

Carrier Key Material: 4130 Steel

Carrier Key Finish: Chrome-lined, DLC (Diamond-like Coating)

Weight: 9.3 oz.